

TIMELESS INSTRUMENTS

VIEWLINE

52MM

INSTRUMENTS

USER MANUAL

rev. AE



EN

DE

IT

FR

ES

PT

CONTENT

Part Numbers	3
Safety information	6
Safety during Installation.....	6
Safety after Installation.....	7
Electrical Connection.....	7
Mechanical Installation	8
Before the Assembly.....	8
Installation with Spinlock.....	9
Flush Mounting.....	10
Installation with Brackets.....	11
Electrical installation	12
Temperature / Pressure / Rudder / Trim / Level Gauges (Resistive).....	13
Level Gauges (Capacitive Sensors).....	14
Exhaust Temperature Gauges (Pyrometer Sensor).....	15
Voltmeter Gauges.....	16
Ammeter Gauges.....	17
Technical Data	19
Accessories	20

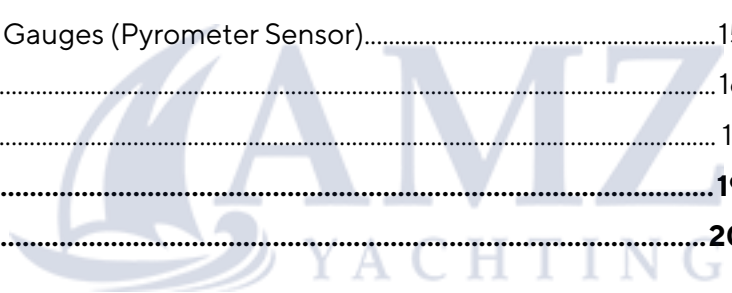

PART NUMBERS

COOLANT TEMPERATURE

Part Number	Dial Color	Dial Scale (outer / inner)	Sensor Input
A2C59514170 A2C59514237	Black White	120 °C / 250 °F	287.4 - 22.7 Ω
A2C59514176 A2C59514241	Black White	250 °F / 120 °C	287.4 - 22.7 Ω

ENGINE OIL TEMPERATURE

Part Number	Dial Color	Dial Scale (outer / inner)	Sensor Input
A2C59514160 A2C59514231	Black White	150 °C / 300 °F	322.8 - 18.6 Ω
A2C59514165 A2C59514234	Black White	300 °F / 150 °C	322.8 - 18.6 Ω

BOOST PRESSURE

Part Number	Dial Color	Dial Scale (outer / inner)	Sensor Input
A2C59514149 A2C59514225	Black White	2 bar / 30 psi	10 - 184 Ω

FRESH WATER LEVEL

Part Number	Dial Color	Dial Scale (outer / inner)	Sensor Input
A2C59514676 A2C59514677	Black White	0 - 1/1	4 - 20 mA
A2C59514097 A2C59514192	Black White	0 - 1/1	3 - 180 Ω
A2C59514099 A2C59514193	Black White	E - F	3 - 180 Ω

ENGINE OIL PRESSURE

Part Number	Dial Color	Dial Scale (outer / inner)	Sensor Input
A2C59514123 A2C59514211	Black White	5 bar / 80 psi	10 - 184 Ω
A2C59514128 A2C59514214	Black White	80 psi / 5 bar	10 - 184 Ω
A2C59514111 A2C59514199	Black White	10 bar / 150 psi	10 - 184 Ω
A2C59514202	White	150 psi / 10 bar	240 - 33.5 Ω

TRANSMISSION OIL PRESSURE

Part Number	Dial Color	Dial Scale (outer / inner)	Sensor Input
A2C59514136 A2C59514206	Black White	25 bar / 350 psi	10 - 184 Ω
A2C59514141 A2C59514208	Black White	30 bar / 435 psi	10 - 184 Ω
A2C59514145 A2C59514223	Black White	400 psi / 25 bar	10 - 184 Ω
A2C1278230001	Black	10 bar	0 - 5 V
A2C1278250001	Black	30 bar	0 - 5 V

FUEL LEVEL

Part Number	Dial Color	Dial Scale (outer / inner)	Sensor Input
A2C59514085 A2C59514186	Black White	E - F	0 - 90 Ω
A2C59514082 A2C59514184	Black White	0 - 1/1	3 - 180 Ω
A2C59514094 A2C59514190	Black White	E - F	240 - 33.5 Ω
A2C59514079 A2C59514182	Black White	0 - 1/1	90 - 4 Ω
A2C59514088 A2C59514188	Black White	E - F	90 - 4 Ω

EXHAUST GAS TEMPERATURE

Part Number	Dial Color	Dial Scale (outer / inner)	Sensor Input
A2C59512332 A2C59512333	Black White	900 °C / 1650 °F	37 mV
A2C59512334 A2C59512335	Black White	1650 °F / 900 °C	37 mV

VOLTMETER

Part Number	Dial Color	Dial Scale (outer / inner)	Sensor Input
A2C59512545 A2C59512546	Black White	8 - 16 V	8 - 16 VDC
A2C59512458 A2C59512459	Black White	18 - 32 V	18 - 32 VDC

WASTE WATER LEVEL

Part Number	Dial Color	Dial Scale (outer / inner)	Sensor Input
A2C59512342	Black	0 - 1/1	4 - 20 mA
A2C59512343	White		

AMMETER

Part Number	Dial Color	Dial Scale (outer / inner)	Sensor Input
A2C59512328	Black	- 60 / + 60 A	60 mV
A2C59512330	White		
A2C59512329	Black	- 150 / + 150 A	60 mV
A2C59512331	White		

RUDDER ANGLE

Part Number	Dial Color	Dial Scale (outer / inner)	Sensor Input
A2C59514154	Black	- 40° / + 40°	3 - 180 Ω
A2C59514230	White		

ENGINE TRIM

Part Number	Dial Color	Dial Scale (outer / inner)	Sensor Input
A2C59514180	Black	UP - DOWN	167 - 10 Ω
A2C59514244	White		

SAFETY INFORMATION

WARNING

- No smoking! No open fire or heat sources!
- The product was developed, manufactured and inspected according to the basic safety requirements of EC Guidelines and state-of-the-art technology.
- The instrument is designed for use in grounded vehicles and machines as well as in pleasure boats, including non-classified commercial shipping.
- Use our product only as intended. Use of the product for reasons other than its intended use may lead to personal injury, property damage or environmental damage. Before installation, check the vehicle documentation for vehicle type and any possible special features!
- Use the assembly plan to learn the location of the fuel/hydraulic/compressed air and electrical lines!
- Note possible modifications to the vehicle, which must be considered during installation!
- To prevent personal injury, property damage or environmental damage, basic knowledge of motor vehicle/shipbuilding electronics and mechanics is required.
- Make sure that the engine cannot start unintentionally during installation!
- Modifications or manipulations to veratron products can affect safety. Consequently, you may not modify or manipulate the product!
- When removing/installing seats, covers, etc., ensure that lines are not damaged and plug-in connections are not loosened!
- Note all data from other installed instruments with volatile electronic memories.

SAFETY DURING INSTALLATION

- During installation, ensure that the product's components do not affect or limit vehicle functions. Avoid damaging these components!
- Only install undamaged parts in a vehicle!
- During installation, ensure that the product does not impair the field of vision and that it cannot impact the driver's or passenger's head!
- A specialized technician should install the product. If you install the product yourself, wear appropriate work clothing. Do not wear loose clothing, as it may get caught in moving parts. Protect long hair with a hair net.
- When working on the on-board electronics, do not wear metallic or conductive jewellery such as necklaces, bracelets, rings, etc.
- If work on a running engine is required, exercise extreme caution. Wear only appropriate work clothing as you are at risk of personal injury, resulting from being crushed or burned.
- Before beginning, disconnect the negative terminal on the battery, otherwise you risk a short circuit. If the vehicle is supplied by auxiliary batteries, you must also disconnect the negative terminals on these batteries! Short circuits can cause fires, battery explosions and damages to other electronic systems. Please note that when you disconnect the battery, all volatile electronic memories lose their input values and must be reprogrammed.
- If working on gasoline boat motors, let the motor compartment fan run before beginning work.
- Pay attention to how lines and cable harnesses are laid so that you do not drill or saw through them!
- Do not install the product in the mechanical and electrical airbag area!
- Do not drill holes or ports in load-bearing or stabilizing stays or tie bars!
- When working underneath the vehicle, secure it according to the specifications from the vehicle manufacturer.

SAFETY INFORMATION

- Drill small ports; enlarge and complete them, if necessary, using taper milling tools, sabre saws, keyhole saws or files. Deburr edges. Follow the safety instructions of the tool manufacturer.
- Use only insulated tools if work is necessary on live parts.
- Use only the multimeter or diode test lamps provided, to measure voltages and currents in the vehicle/machine or boat. Use of conventional test lamps can cause damage to control units or other electronic systems.
- The electrical indicator outputs and cables connected to them must be protected from direct contact and damage. The cables in use must have enough insulation and electric strength and the contact points must be safe from touch.
- Use appropriate measures to also protect the electrically conductive parts on the connected consumer from direct contact. Laying metallic, uninsulated cables and contacts is prohibited.

SAFETY AFTER INSTALLATION

- Connect the ground cable tightly to the negative terminal of the battery.
- Reenter/reprogram the volatile electronic memory values.
- Check all functions.
- Use only clean water to clean the components. Note the Ingress Protection (IP) ratings (IEC 60529).

ELECTRICAL CONNECTION

- Note cable cross-sectional area!
- Reducing the cable cross-sectional area leads to higher current density, which can cause the cable cross-sectional area in question to heat up!
- When installing electrical cables, use the provided cable ducts and harnesses; however, do not run cables parallel to ignition cables or to cables that lead to large electricity consumers.
- Fasten cables with cable ties or adhesive tape. Do not run cables over moving parts. Do not attach cables to the steering column!
- Ensure that cables are not subject to tensile, compressive or shearing forces.
- If cables are run through drill holes, protect them using rubber sleeves or the like.
- Use only one cable stripper to strip the cable. Adjust the stripper so that stranded wires are not damaged or separated.
- Use only a soft soldering process or commercially available crimp connector to solder new cable connections!
- Make crimp connections with cable crimping pliers only. Follow the safety instructions of the tool manufacturer.
- Insulate exposed stranded wires to prevent short circuits.
- Caution: Risk of short circuit if junctions are faulty or cables are damaged.
- Short circuits in the vehicle network can cause fires, battery explosions and damages to other electronic systems. Consequently, all power supply cable connections must be provided with weldable connectors and be sufficiently insulated.
- Ensure ground connections are sound.
- Faulty connections can cause short circuits. Only connect cables according to the electrical wiring diagram.
- If operating the instrument on power supply units, note that the power supply unit must be stabilized and it must comply with the following standard: DIN EN 61000, Parts 6-1 to 6-4.

MECHANICAL INSTALLATION

⚠ WARNING

- Before beginning, disconnect the negative terminal on the battery, otherwise you risk a short circuit.
- If the vehicle is supplied by auxiliary batteries, you must also disconnect the negative terminals on these batteries! Short circuits can cause fires, battery explosions and damages to other electronic systems. Please note that when you disconnect the battery, all volatile electronic memories lose their input values and must be reprogrammed.

BEFORE THE ASSEMBLY

1. Before beginning, turn off the ignition and remove the ignition key. If necessary, remove the main circuit switch.

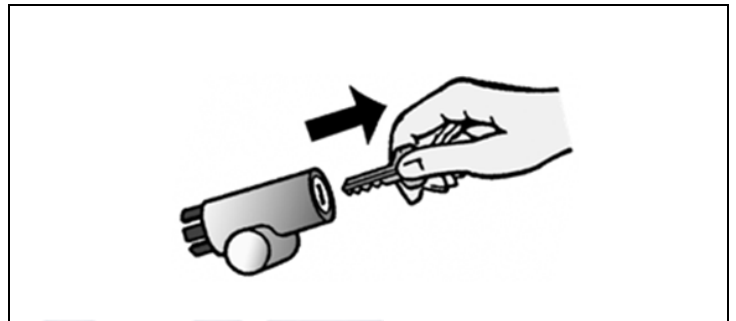

2. Disconnect the negative terminal on the battery. Make sure the battery cannot unintentionally restart.

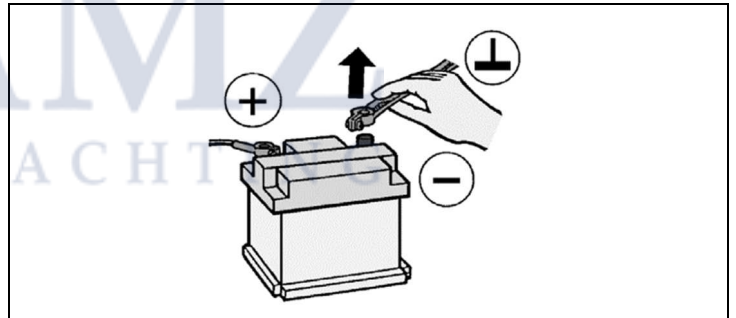

3. Place the device at least 500 mm away from any magnetic compass.

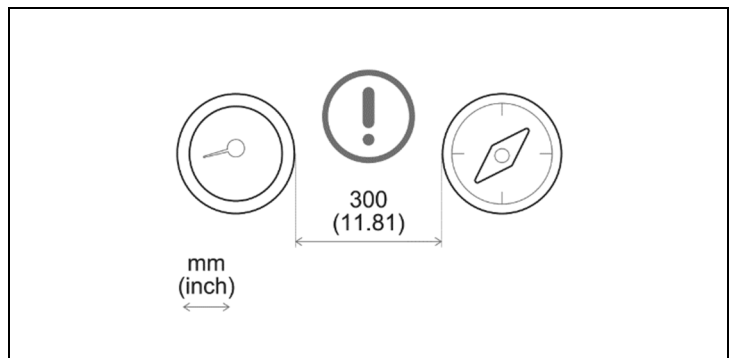

INSTALLATION WITH SPINLOCK

Conventional assembly. (Instrument is put into the drill hole from the front). The panel width may be within a range of 0.5 to 20 mm. The drill hole must have a diameter of 53 mm **[B]**.

⚠ WARNING

- Do not drill holes or ports in load-bearing or stabilizing stays or tie bars!
- Note the necessary clearance behind the drill hole or port at the installation location. Required mounting depth: 65 mm.
- Drill small ports; enlarge and complete them, if necessary, using taper milling tools, saber saws, keyhole saws or files. Deburr edges. Follow the safety instructions of the tool manufacturer.

1. Different bezels may be installed as alternatives to the supplied front ring. In this case, gently remove the bezel using a screwdriver **[A]** and install the new bezel on the instrument and press it on until it is flush with the instrument glass.

Note: the bezel cannot be used after removal since it can be damaged.

IMPORTANT: if installing a chrome bezel, make sure to configure the device **BEFORE** installing it, as the metallic particles contained in the chrome material might affect the NFC performance!

2. Create a circular hole in the panel considering the device dimensions. **[B]**

3. Remove the spinlock and insert the device from the front. **[C]**

4. Adjust the spinlock as shown in picture **[D]** according to the panel thickness

5. Carefully screw in the spinlock by hand at least two turns.

6. Insert the connector.

A

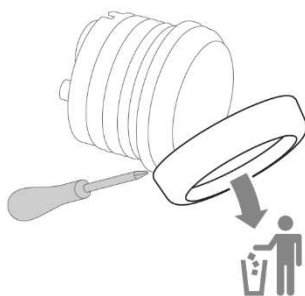

B

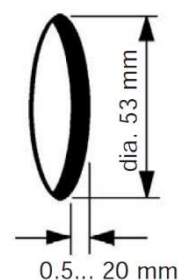

C

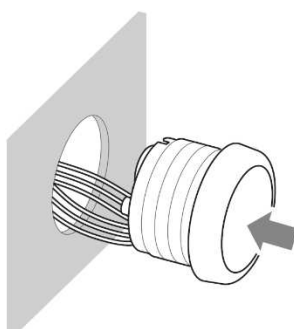

D

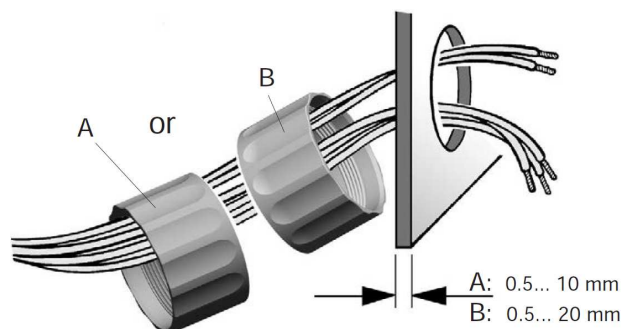

FLUSH MOUNTING

The recommended panel thickness is 1.5 to 3 mm. The drill hole must have a diameter of 48.1 mm. [A]

Ensure that the installation location is level and has no sharp edges.

⚠ WARNING

- Do not drill holes or ports in load-bearing or stabilizing stays or tie bars!
- Note the necessary clearance behind the drill hole or port at the installation location. Required mounting depth: 65 mm.
- Drill small ports; enlarge and complete them, if necessary, using taper milling tools, saber saws, keyhole saws or files. Deburr edges. Follow the safety instructions of the tool manufacturer.

1. Create a circular hole in the panel considering the device dimensions. [A]

2. Remove the spinlock.

3. Gently remove the bezel using a screwdriver. [B]

Note: the bezel cannot be used after removal since it can be damaged.

4. Place the flush mount seal A2C53215640 (not included) on the instrument glass.

5. Put the instrument into the drill hole from the back [C].

6. Adjust the instrument so that the gauge is level and fasten it to the stud bolts on the rear side of the panel, using the flush mount fixing bracket A2C59510864 (not included) [D].

7. Insert the connector.

A

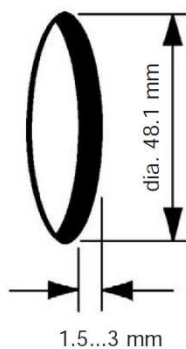

B

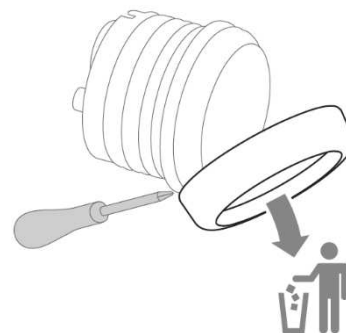

C

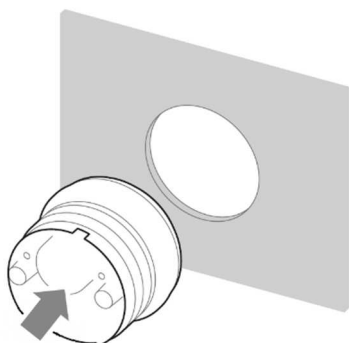

D

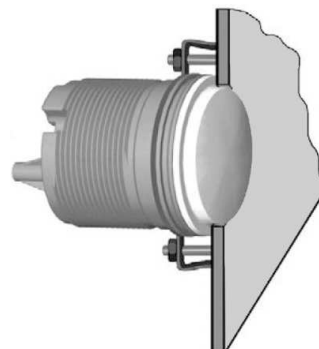

INSTALLATION WITH BRACKETS

Conventional assembly. (Instrument is put into the drill hole from the front).

The panel width may be within a range of 0.5 to 20 mm. The drill hole must have a diameter of 53 mm.

WARNING

- Do not drill holes or ports in load-bearing or stabilizing stays or tie bars!
- Note the necessary clearance behind the drill hole or port at the installation location. Required mounting depth: 65 mm.
- Drill small ports; enlarge and complete them, if necessary, using taper milling tools, saber saws, keyhole saws or files. Deburr edges. Follow the safety instructions of the tool manufacturer.

1. Create a circular hole in the panel considering the device dimensions.

2. Remove the spinlock and insert the device from the front.

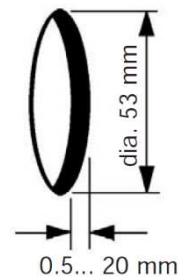

3. Screw the stud bolts into the provided drill holes in the enclosure.

Max. stud bolt torque is 1.5 Nm.

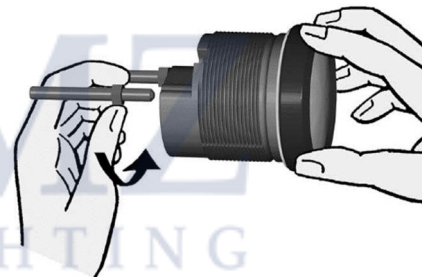

4. Place the bracket on the stud bolt and hand-tighten the knurled nut.

5. Make sure the seal lays flat between the panel and the front ring.

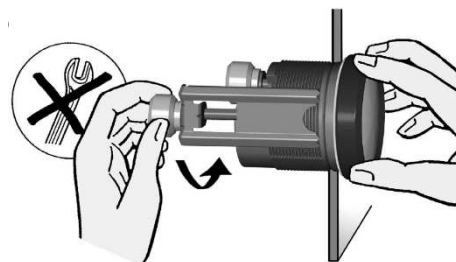

ELECTRICAL INSTALLATION

⚠ WARNING

- Refer to the safety rules described in the electrical connections section of the safety information chapter of this document!

Depending on the configuration, insert the cable into the 8-pin contact enclosure according to the following pin assignment.

The contacts must audibly lock into place.

Now insert the plug into the gauge.

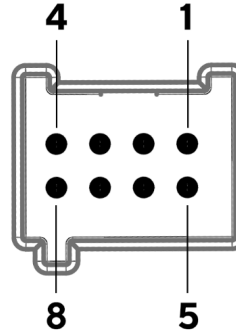

Note the inverse polarity protection nose in the process.

Pin No.	Wire color	Description
1	Red	KL. 15 - Ignition plus
2	Black	KL. 31 - Ground
3	Black / Blue	Sensor ground *
4	Brown	KL. 30 - Battery Power 12 / 24 V
5	Green	Sensor signal *
6	Blue / Red	KL. 58 - Illumination
7	Yellow / Black	Warning LED ground
8	Yellow / Red	Warning LED plus

* not connected on voltmeter instruments

**CONNECTION DIAGRAM FOR:
TEMPERATURE / PRESSURE / RUDDER / TRIM / LEVEL GAUGES (RESISTIVE)**

Designations in the wiring diagrams:

30 – Term. 30 – steady-state plus
12 V

58 – Term. 58 – lighting

F1 – Fuse 5A quick-response

15 – Term. 15 – ignition plus

31 – Term. 31 – ground

L1 – External warning lamp
(max.1 A)

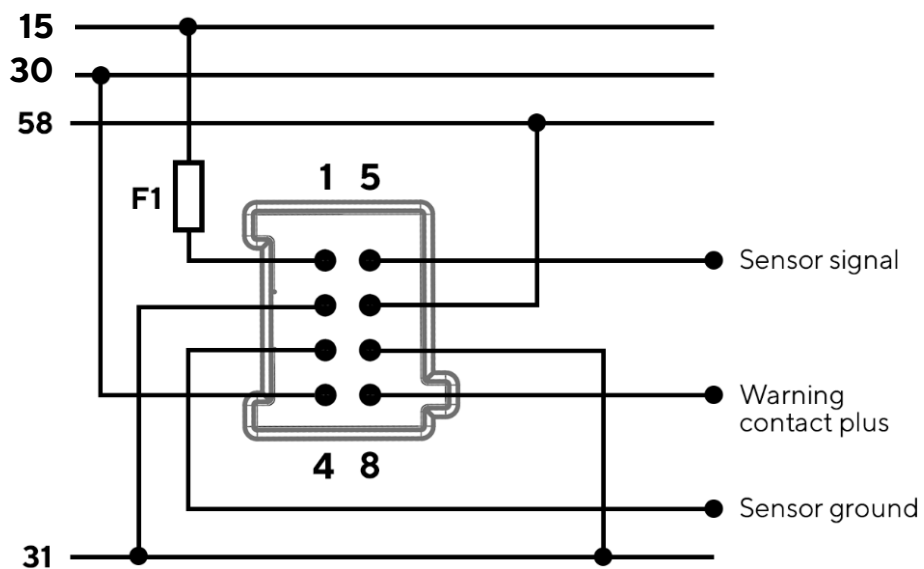
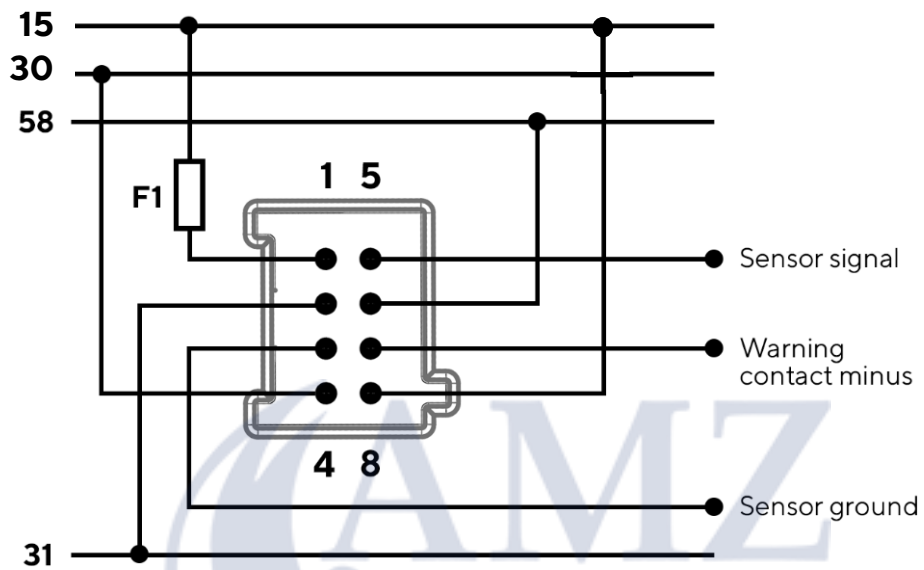

CONNECTION DIAGRAM FOR: LEVEL GAUGES (CAPACITIVE SENSORS)

Connections to sensors:

N02-240 /-402 /-404 /-406

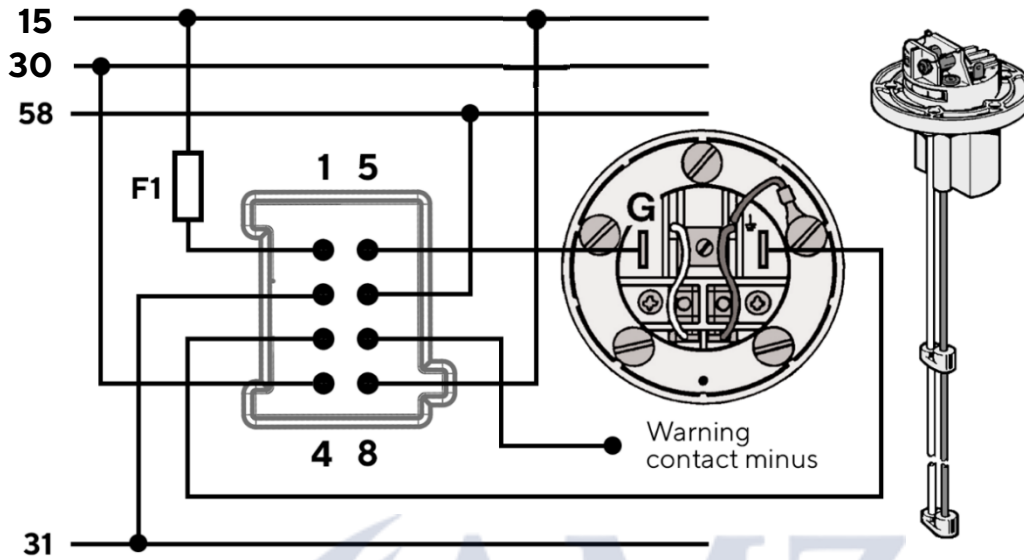

Connection to sensors:

N02-240-/-802 /-902 /-904 /-906

1	Green	2	Yellow
3	White	4	Brown

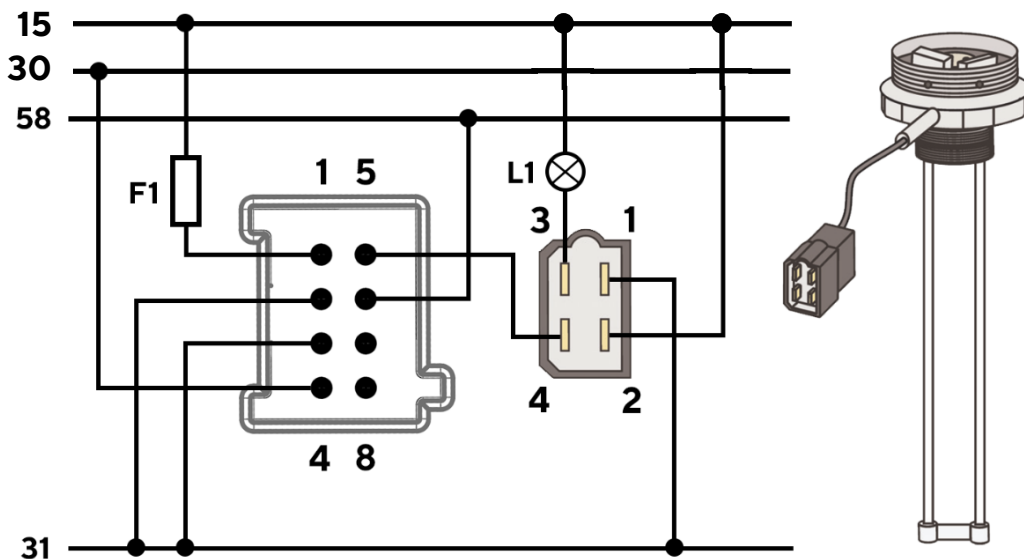

CONNECTION DIAGRAM FOR: EXHAUST TEMPERATURE GAUGES (PYROMETER SENSOR)

⚠ WARNING

- Do not shorten the measuring lead!

Connection to pyrometer sensor
N03-320-264 via 6 m extension
cable B00063201.

Extension Cable

A	Blue	GND
C	White	Signal

Pyrometer sensor

B	Red	GND
D	Yellow	Signal

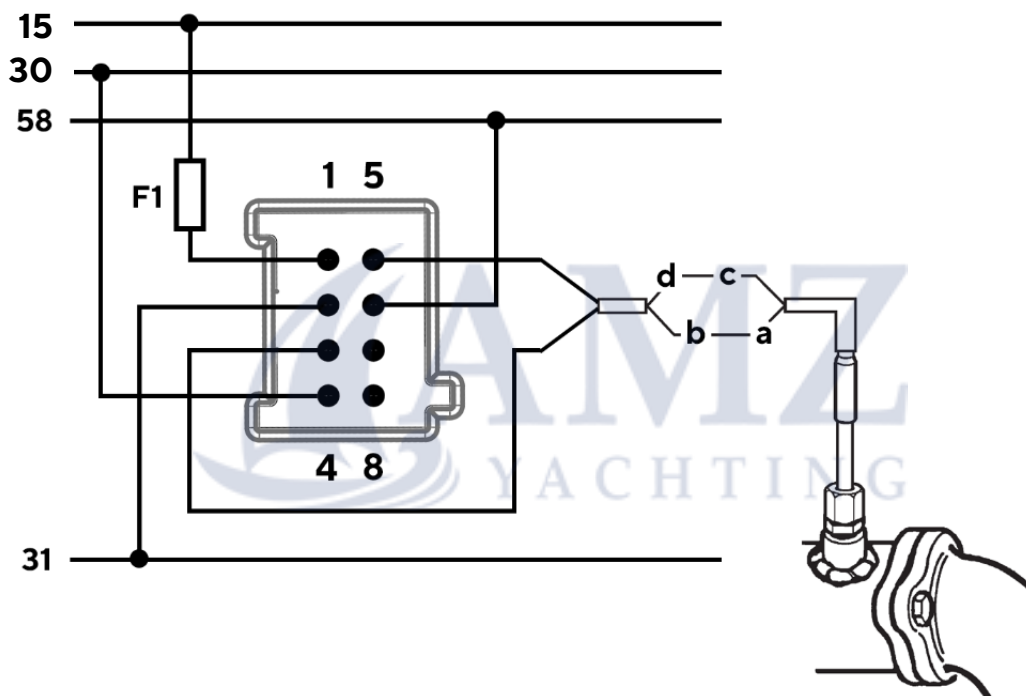

CONNECTION DIAGRAM FOR:
VOLTMETER GAUGES

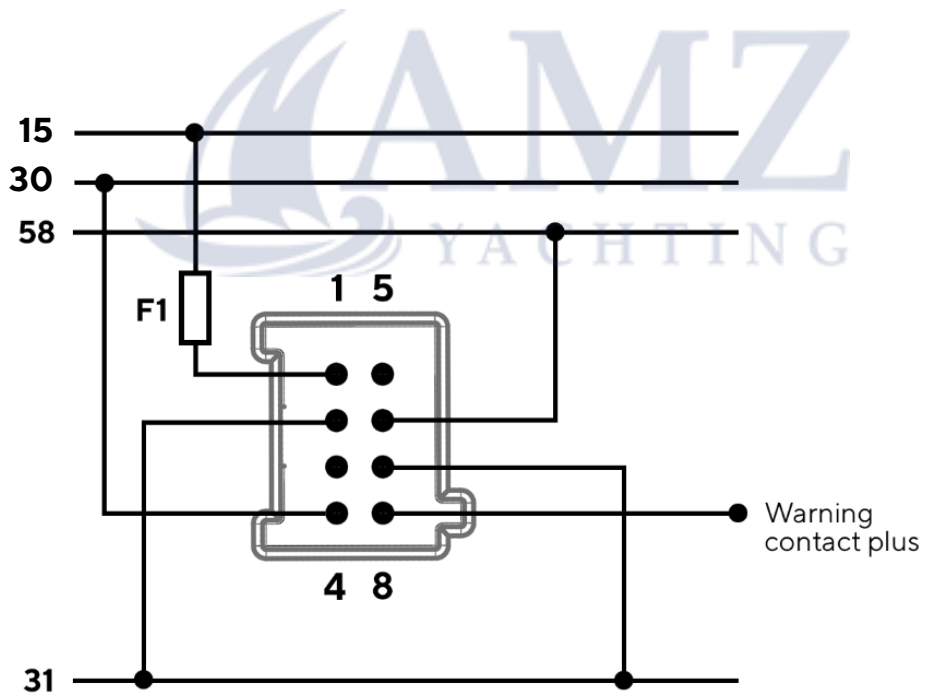
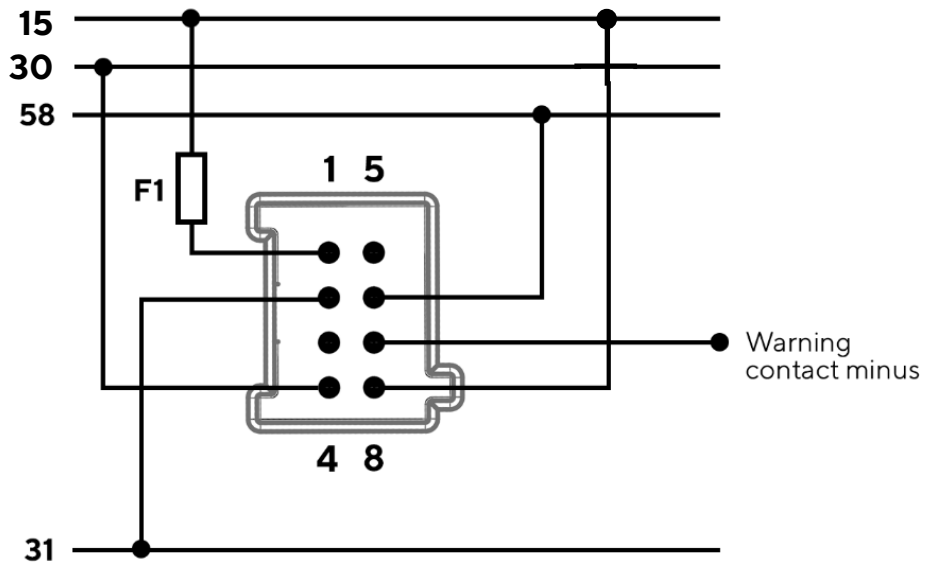

CONNECTION DIAGRAM FOR: AMMETER GAUGES

Connection to the ammeter shunt

A2C59514043 (60 A) and A2C59514047 (150 A) via 10 m extension cable
A2C59512679.

Designations in the wiring diagrams:

30 - Term. 30 - steady-state plus 12 V	31 - Term. 31 - ground	B1 - Battery
15 - Term. 15 - ignition plus	F1 - Fuse 5A quick-response	S1 - Starter
58 - Term. 58 - lighting	A1 - Alternator	

⚠ WARNING

- Do not shorten the 10 m measuring lead (cables a and b)!

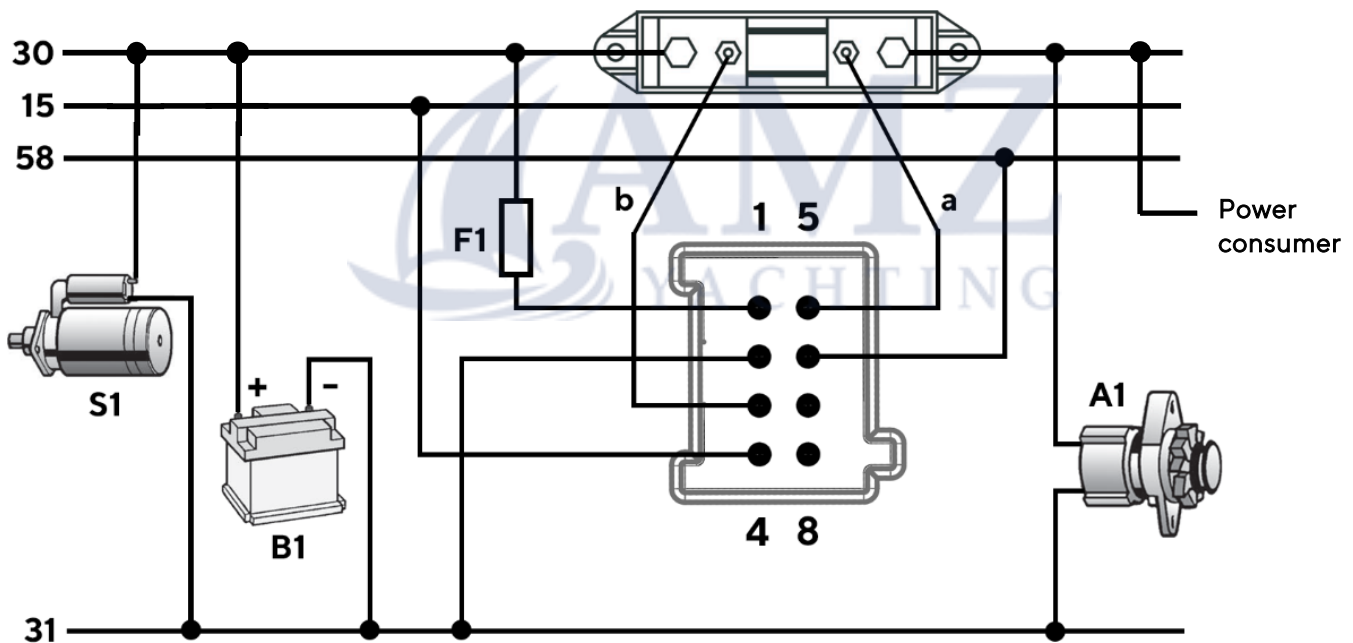

The starter current should not go through the shunt.

⚠ WARNING

- Pinout is NOT the same as for other gauges!

⚠ WARNING

- Do not reduce the existing cable cross section!

c	Green
d	Blue / Black

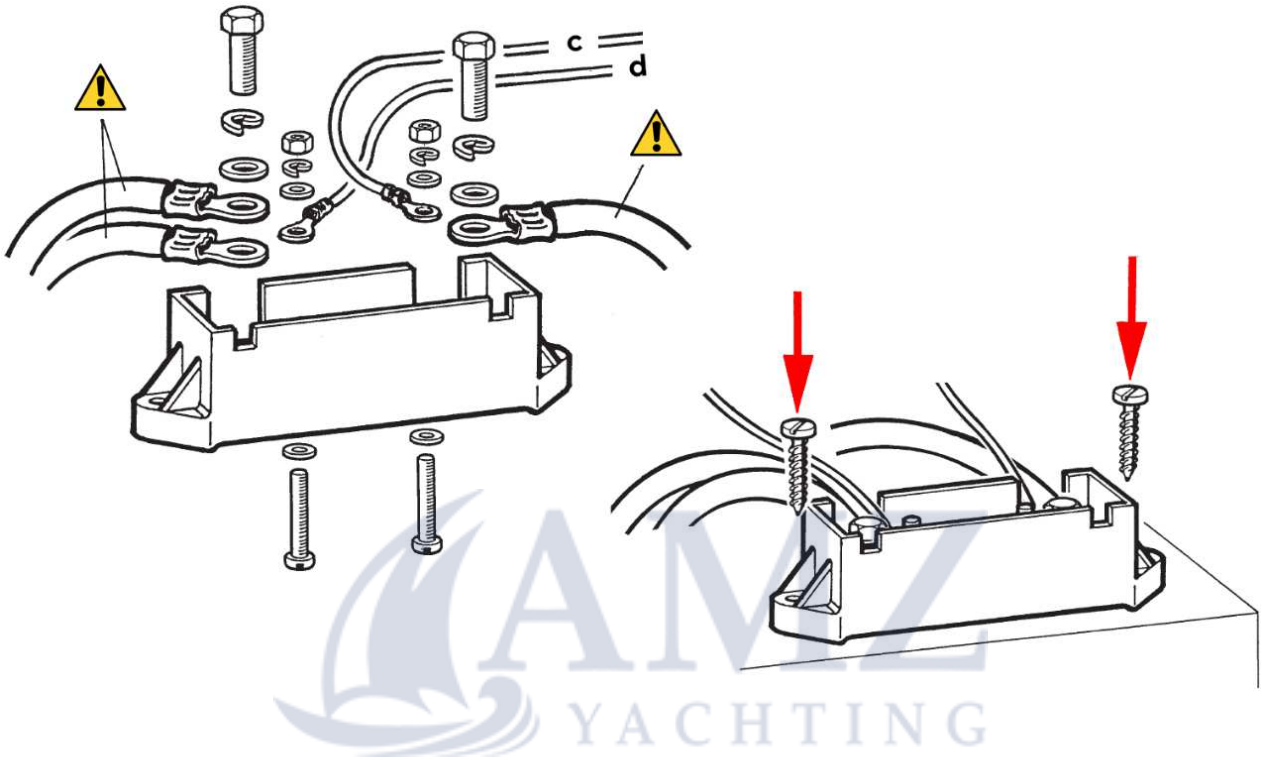

General Terminal Diagram:

In special cases, show the ship's electrical diagram to your boatyard or to a branch or agent and ask for advice on how to connect the sensors.

TECHNICAL DATA

DATASHEET

Nominal Voltage	12 V / 24 V
Operating Voltage	10 - 32 V with overvoltage and reverse polarity protection
Current consumption	< 140 mA with warning LED
Protection class	IP 67 front side, IP 52 rear side acc. IEC60529
Lens	PMMA double lens
Housing	Ø52 mm - Polycarbonate (PC)
Installation depth	50 mm
Bezels	PC (black, white) or ABS (chrome) - several color and shapes
Dial	Backlit, different colors (black, white)
Pointer	Backlit, white on black dials; red on white dials 90° and 270° deflection angle
Illumination	Dial: LED amber (605 nm) Pointer: LED red (632 nm)
Warning LED	Red (632 nm)
Operating temperature	-30°C to +80°C with chrome bezel -30°C to +70°C
Storage temperature	-30°C to +80°C with chrome bezel -30°C to +70°C
Flammability	flame retardant acc. UL94-V0
Connector	Tyco / Hirschmann MQS connector 8 pins
Mounting	Spinlock Nut - locking height 0.5 - 20 mm Optional Studs and Brackets - locking height 2 - 15 mm
Certifications	CE, Reach, RoHS

ACCESSORIES

Description	Part Number
Adapter cable 8-poles	A2C59512947
10 m Ammeter harness	A2C59512679
Spinlock Nut 52 mm	A2C5205947101
Flush mount mounting kit	A2C59510864
Flush mount seal	A2C53215640
Bracket assembly mounting kit	A2C59510854
Connector set 8 pins	A2C59510850
Blind plug for 52 mm	A2C5312164501
Bezel - Round Black	A2C5318602701
Bezel - Round White	A2C5318602801
Bezel - Round Chrome	A2C5318602901
Bezel - Triangular Black	A2C5318602401
Bezel - Triangular White	A2C5318602501
Bezel - Triangular Chrome	A2C5318602601
Bezel - Flat Black	A2C5318604001
Bezel - Flat White	A2C5318602201
Bezel - Flat Chrome	A2C5318602301

Visit <http://www.veratron.com> for the complete list of accessories.



veratron AG
Industriestrasse 18
9464 Rüthi, Switzerland

T +41 71 7679 111
info@veratron.com
veratron.com

Any distribution, translation or reproduction, partial or total, of the document is strictly prohibited unless with prior authorization in writing from veratron AG, except for the following actions:

Printing the document in its original format, totally or partially.
Copying contents without any modifications and stating veratron AG as copyright owner.

Veratron AG reserves the right to make modifications or improvements to the relative documentation without notice.

Requests for authorization, additional copies of this manual or technical information on the latter, must be addressed to veratron AG.